

ELEVATION CERTIFICATE

O.M.B. No. 3067-0077

Expires July 31, 1999

FEDERAL EMERGENCY MANAGEMENT AGENCY
NATIONAL FLOOD INSURANCE PROGRAM

ATTENTION: Use of this certificate does not provide a waiver of the flood insurance purchase requirement. This form is used only to provide elevation information necessary to ensure compliance with applicable community floodplain management ordinances, to determine the proper insurance premium rate, and/or to support a request for a Letter of Map Amendment or Revision (LOMA or LOMR). You are not required to respond to this collection of information unless a valid OMB control number is displayed in the upper right corner of this form.

Instructions for completing this form can be found on the following pages.

SECTION A PROPERTY INFORMATION
FOR INSURANCE COMPANY USE
BUILDING OWNER'S NAME: SOUTHWEST FLORIDA HOME BUILDERS INC.
STREET ADDRESS: 151 DELBROOK WAY
OTHER DESCRIPTION: LOT 21, BLOCK 790, MARCO BEACH UNIT TWENTY FIVE
CITY: MARCO ISLAND STATE: FLORIDA ZIP CODE: 34145

SECTION B FLOOD INSURANCE RATE MAP (FIRM) INFORMATION

Provide the following from the proper FIRM (See Instructions):

Table with 6 columns: 1. COMMUNITY NUMBER (120426), 2. PANEL NUMBER (0812), 3. SUFFIX (E), 4. DATE OF FIRM INDEX (JULY 20, 1998), 5. FIRM ZONE (AE), 6. BASE FLOOD ELEVATION (10.0)

- 7. Indicate the elevation datum system used on the FIRM for Base Flood Elevations (BFE): [] NGVD '29 [] Other (describe on back)
8. For Zones A or V, where no BFE is provided on the FIRM, and the community has established a BFE for this building site, indicate the community's BFE: [] feet NGVD (or other FIRM datum—see Section B, Item 7).

SECTION C BUILDING ELEVATION INFORMATION

- 1. Using the Elevation Certificate Instructions, indicate the diagram number from the diagrams found on Pages 5 and 6 that best describes the subject building's reference level: 1
2(a). FIRM Zones A1-A30, AE, AH, and A (with BFE). The top of the reference level floor from the selected diagram is at an elevation of [] feet NGVD (or other FIRM datum—see Section B, Item 7). GARAGE FLOOR ELEV. = 8.1
(b). FIRM Zones V1-V30, VE, and V (with BFE). The bottom of the lowest horizontal structural member of the reference level from the selected diagram, is at an elevation of [] feet NGVD (or other FIRM datum—see Section B, Item 7).
(c). FIRM Zone A (without BFE). The floor used as the reference level from the selected diagram is [] feet above [] or below [] (check one) the highest grade adjacent to the building.
(d). FIRM Zone AO. The floor used as the reference level from the selected diagram is [] feet above [] or below [] (check one) the highest grade adjacent to the building. If no flood depth number is available, is the building's lowest floor (reference level) elevated in accordance with the community's floodplain management ordinance? [] Yes [] No [] Unknown
3. Indicate the elevation datum system used in determining the above reference level elevations: [X] NGVD '29 [] Other (describe under Comments on Page 2).
4. Elevation reference mark used appears on FIRM: [] Yes [X] No (See Instructions on Page 4)
5. The reference level elevation is based on: [X] actual construction [] construction drawings
6. The elevation of the lowest grade immediately adjacent to the building is: [] feet NGVD (or other FIRM datum—see Section B, Item 7).

SECTION D COMMUNITY INFORMATION

- 1. If the community official responsible for verifying building elevations specifies that the reference level indicated in Section C, Item 1 is not the "lowest floor" as defined in the community's floodplain management ordinance, the elevation of the building's "lowest floor" as defined by the ordinance is: [] feet NGVD (or other FIRM datum—see Section B, Item 7).
2. Date of the start of construction or substantial improvement: 6-2-99

* SEE NOTE (under)

Permit # 992428

This certification is to be signed by a land surveyor, engineer, or architect who is authorized by state or local law to certify elevation information when the elevation information for Zones A1-A30, AE, AH, A (with BFE), V1-V30, VE, and V (with BFE) is required. Community officials who are authorized by local law or ordinance to provide floodplain management information, may also sign the certification. In the case of Zones AO and A (without a FEMA or community issued BFE), a building official, a property owner, or an owner's representative may also sign the certification.

Reference level diagrams 6, 7 and 8 - Distinguishing Features-If the certifier is unable to certify to breakaway/non-breakaway wall, enclosure size, location of servicing equipment, area use, wall openings, or unfinished area Feature(s), then list the Feature(s) not included in the certification under Comments below. The diagram number, Section C, Item 1, must still be entered.

I certify that the information in Sections B and C on this certificate represents my best efforts to interpret the data available.
I understand that any false statement may be punishable by fine or imprisonment under 18 U.S. Code, Section 1001.

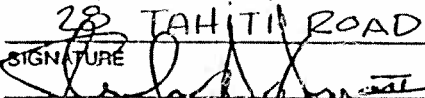
CERTIFIER'S NAME STEPHEN A. HIGGINS III		LICENSE NUMBER (or Affix Seal) LS 5194	
TITLE LAND SURVEYOR & MAPPER		COMPANY NAME MARCO ISLAND LAND SURVEYOR	
ADDRESS 28 TAHITI ROAD		CITY MARCO ISLAND	STATE ZIP FL. 34145
SIGNATURE 		DATE JULY 30, 1999	PHONE 941-389-2385

Copies should be made of this Certificate for: 1) community official, 2) insurance agent/company, and 3) building owner.

COMMENTS: AS REQUESTED BY THE CITY OF MARCO ISLAND THE COMMUNITY
PANEL NUMBER IS SHOWN AS 120426 AND THE DATE IS SHOWN AS
JULY 20, 1998. REFERENCE IS MADE TO A LETTER FROM THE FEDERAL
EMERGENCY MANAGEMENT, DATED DEC. 1, 1998 TO MAYOR MOSS.

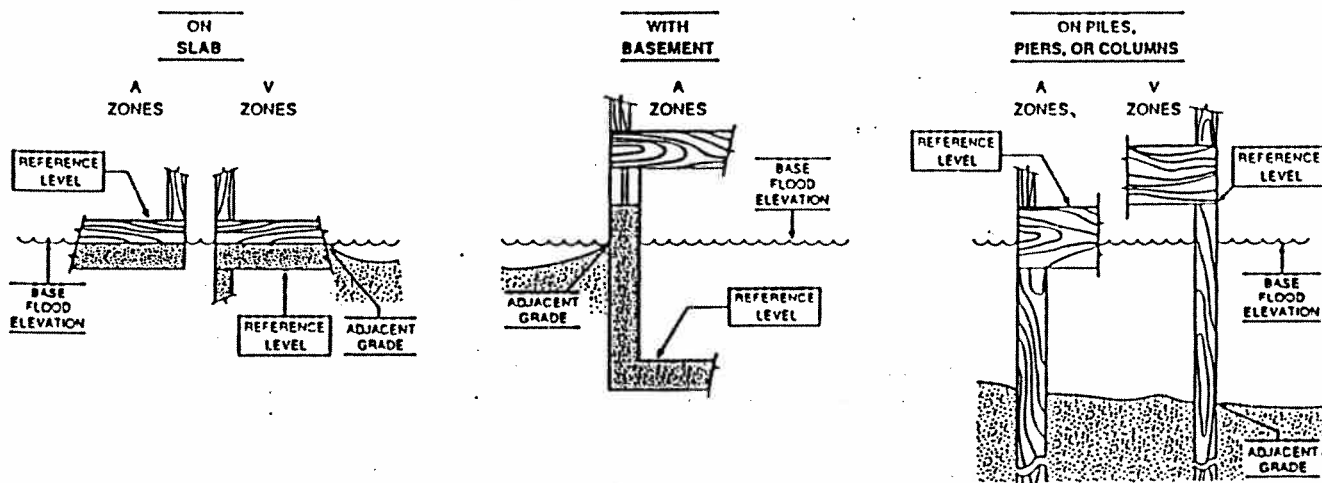

The diagrams above illustrate the points at which the elevations should be measured in A Zones and V Zones.

Elevations for all A Zones should be measured at the top of the reference level floor.

Elevations for all V Zones should be measured at the bottom of the lowest horizontal structural member.